

CUT LICENSE NUMBERS FROM BLACK PAPER

NC34820

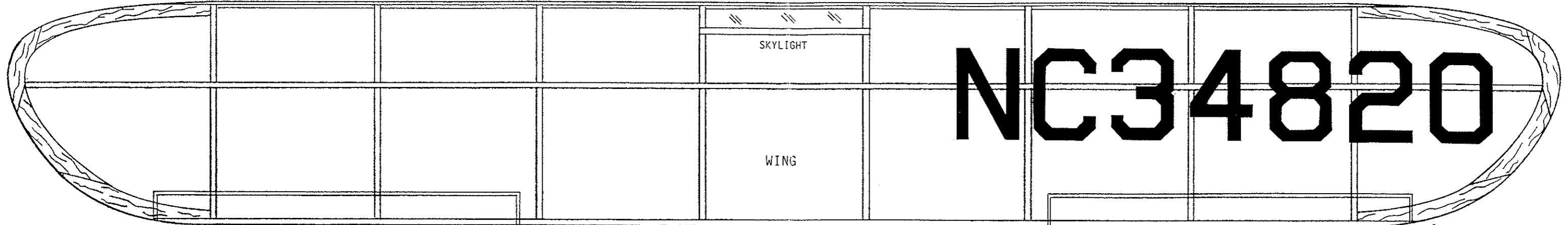

OUTLINE CONTROLS WITH BLACK PAPER STRIPS

ROLL WING TIPS UNDER PENCIL TO CURVE UPWARD AS SHOWN ON FRONT VIEW

THREAD TAIL RIGGING

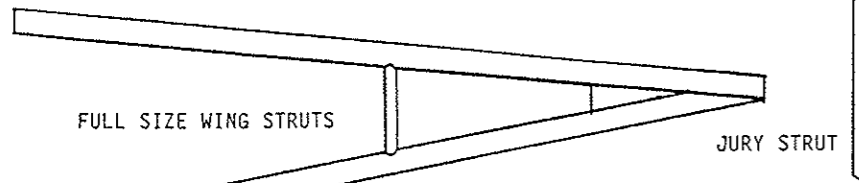

COLOR SCHEME
ALL YELLOW WITH
BLACK LETTERING

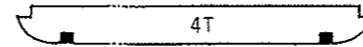

1/4" DIHEDRAL
UNDER END RIB

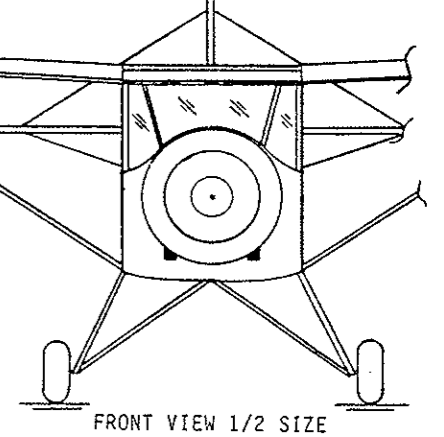
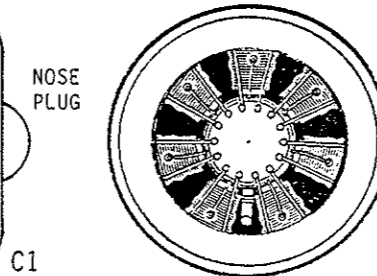

FRONT VIEW 1/2 SIZE

LICENSE NUMBERS AND
AIRLINE EMBLEM ON BOTH SIDES OF RUDDER

NC
3
4
8
2
0

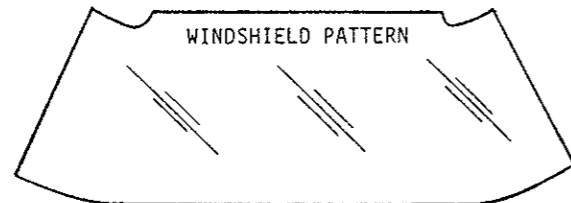
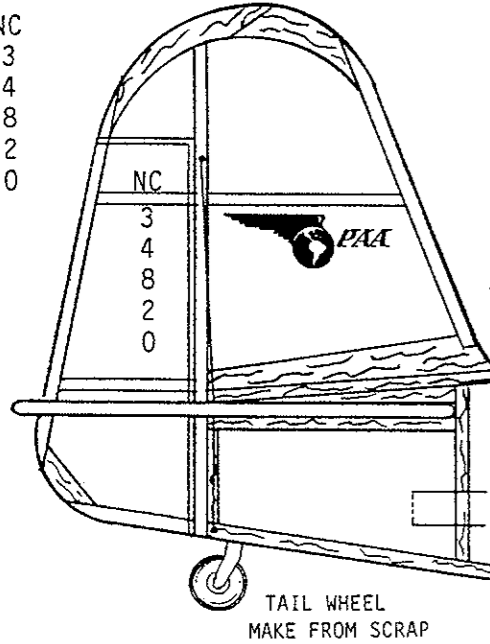

WINDSHIELD PATTERN

PAN AMERICAN AIRWAYS SYSTEM

CUT LETTERING FROM PLAN AND STICK TO FUSELAGE SIDES IN OUTLINED BLOCK

PAN AMERICAN AIRWAYS SYSTEM

NOTCH TWO RIBS FOR SKYLIGHT

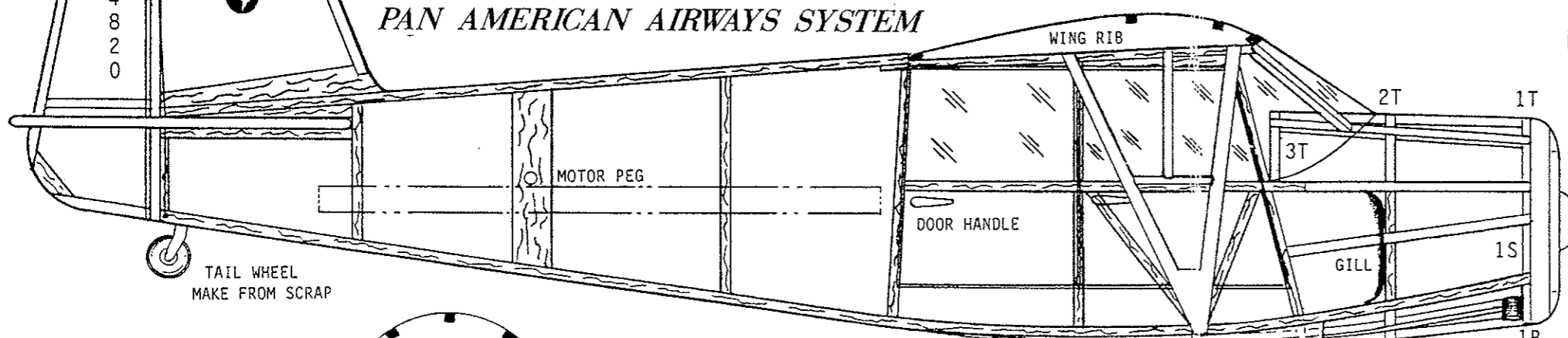

CUT MOTOR FROM PLAN AND
STICK TO FRONT OF C2

C2
C2 IS 1/8 THICK

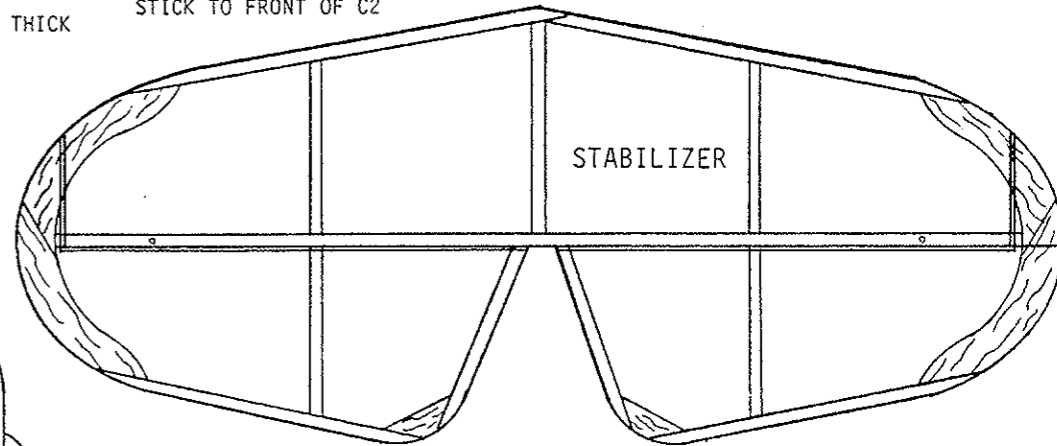

STABILIZER

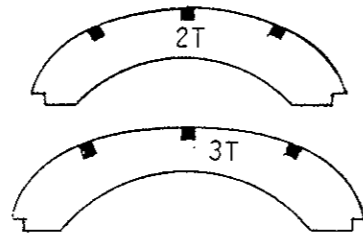
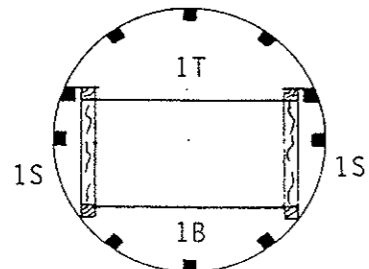
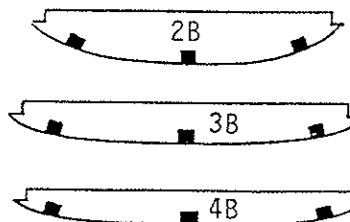

DOORS ON RIGHT SIDE ONLY

FAT 3/4 INCH WHEELS
USE PIN FOR AXLE

DRAW AIR OUTLET GILL
ON BOTH SIDES OF FUSELAGE
WITH INK

FULL SIZE L.G. STRUTS

AIRDEVIL MODEL CO.

REARWIN INSTRUMENT TRAINER

WINGSPREAD-16 INCHES PRICE- 10¢

DRAWN BY- R. RUMMELL

TEST PILOT O.K.- BILL MILLER