

CONTROLS OUTLINED WITH BLACK PAPER STRIPS

BOTTOM WING SHOWN IN DASHED LINES

CRACK HERE FOR DIHEDRAL FOR TOP WING

LICENSE NUMBERS CUT FROM BLACK PAPER
STICK TO TOP OF RIGHT WING AND BOTTOM OF LEFT WING

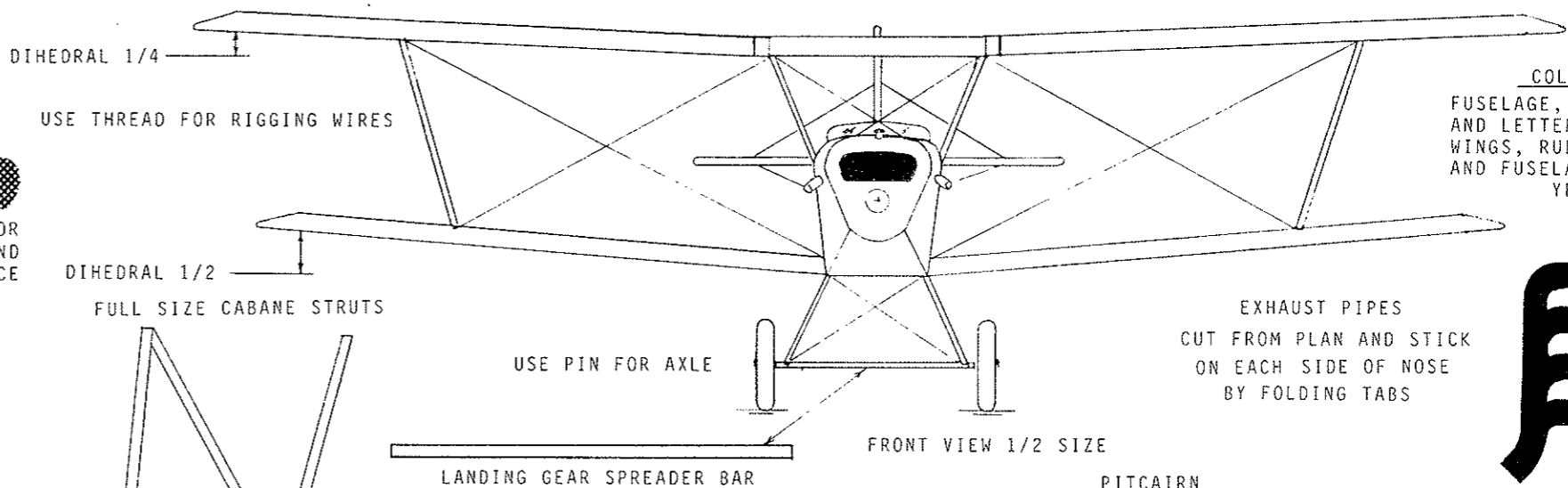
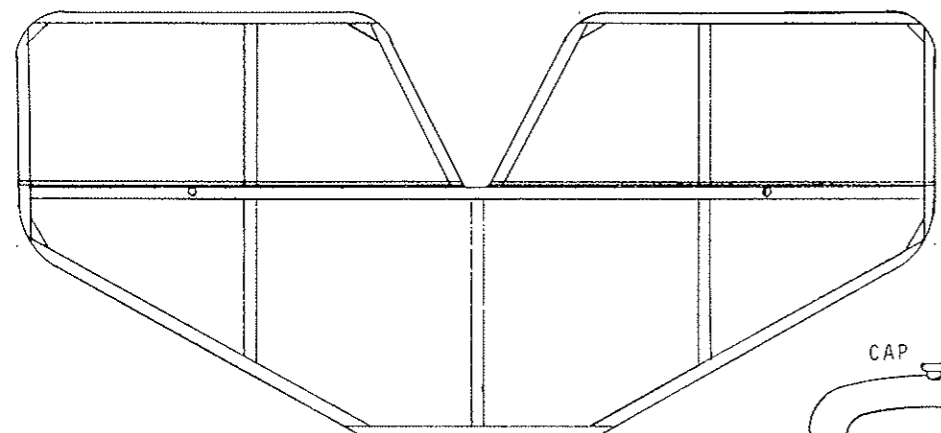

COLOR SCHEME:
FUSELAGE, STRUTS, WHEELS, AND LETTERING ARE BLACK. WINGS, RUDDER, STABILIZER, AND FUSELAGE ARROWS ARE YELLOW.

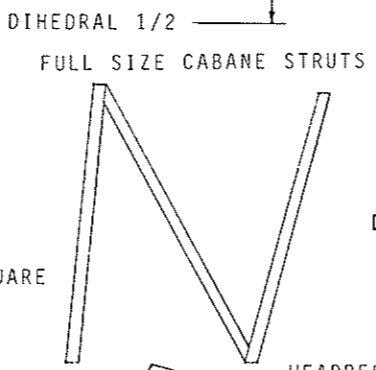
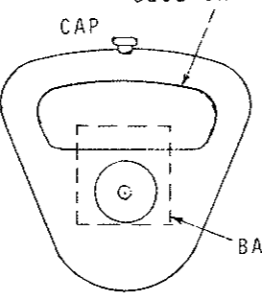
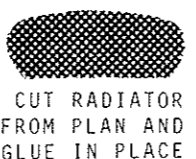

EXHAUST PIPES CUT FROM PLAN AND STICK ON EACH SIDE OF NOSE BY FOLDING TABS

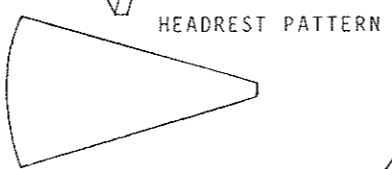
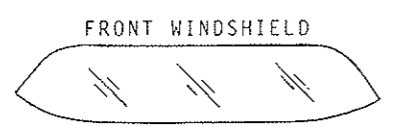
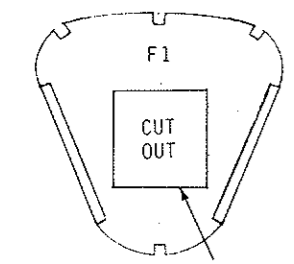
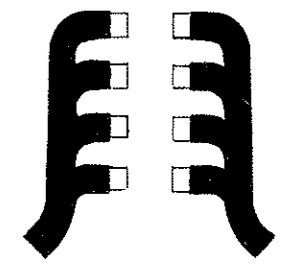

LETTERING ON BOTH SIDES OF RUDDER

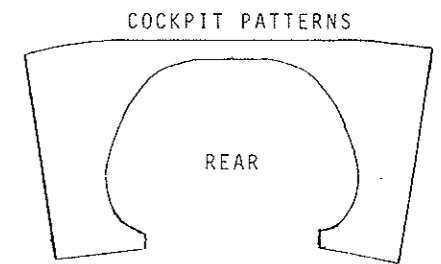
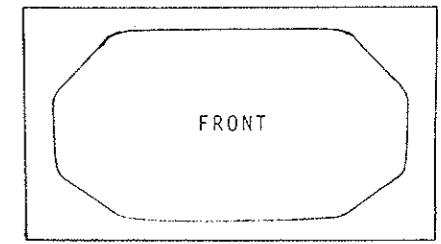

GLUE BALSA SQUARE TO BACK OF NOSE BLOCK

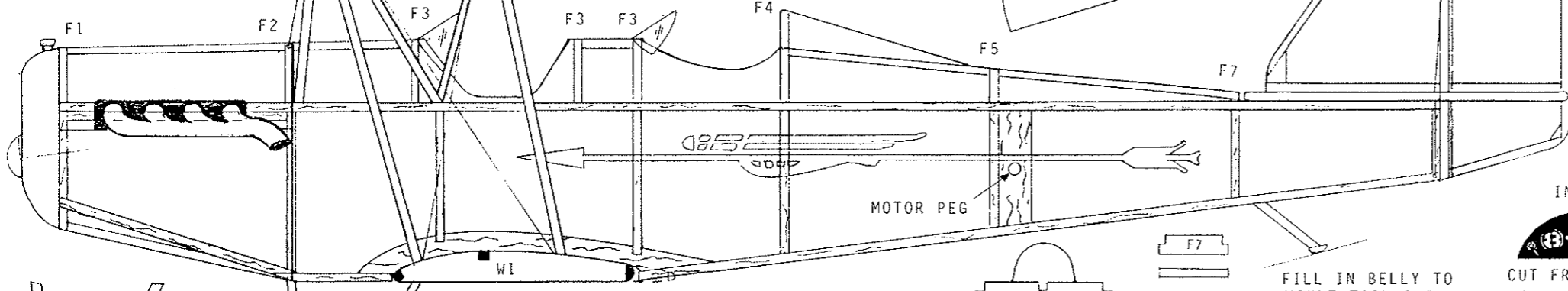

FULL SIZE BAY STRUTS

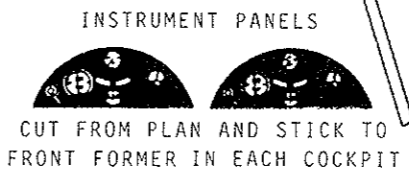

FILL IN BELLY TO MOUNT TAIL SKID

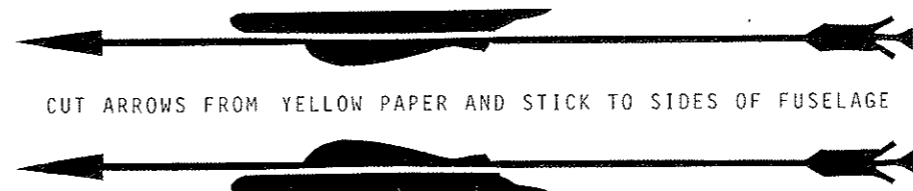
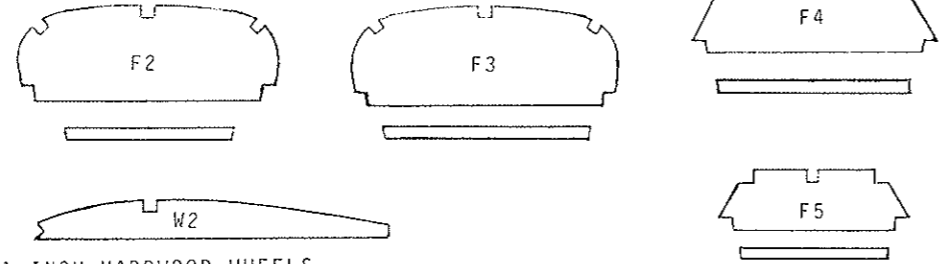

FULL SIZE LANDING GEAR STRUTS

1 INCH HARDWOOD WHEELS

★ AIRDEVIL MODEL CO. ★

PITCAIRN FLEETWING

WINGSPREAD-16" PRICE- 10¢

DRAWN BY- NOTSO NIETO

TEST PILOT O.K.- WYLAM WILLIAMS

11.19.78