

CUT CONTROL OUTLINES FROM BLACK PAPER AND STICK IN PLACE

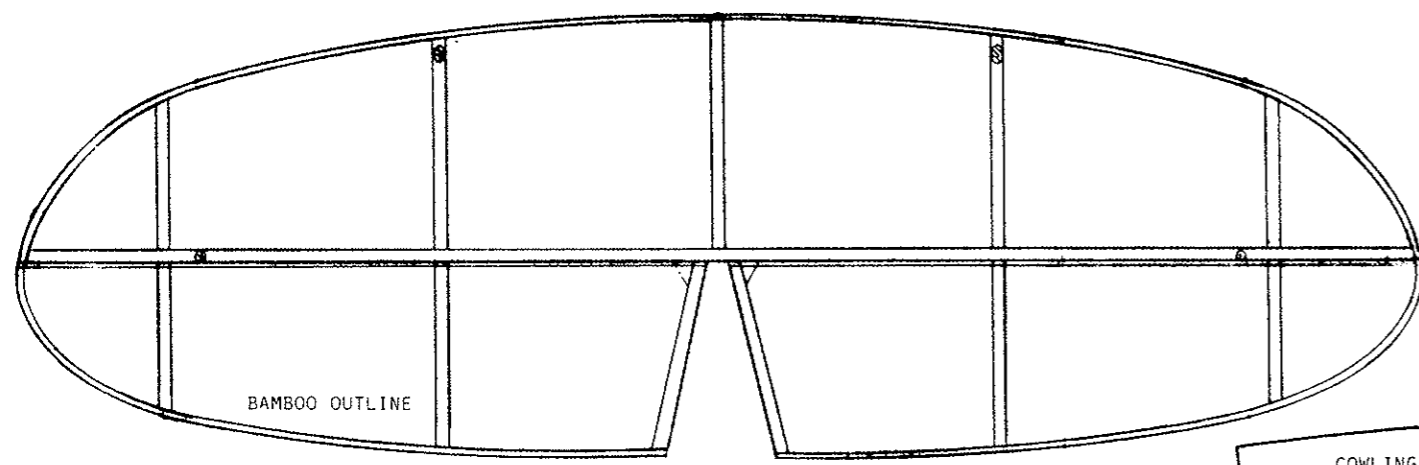

BAMBOO OUTLINE

CUT MOTOR FROM PLAN AND STICK TO FRONT OF COWLING

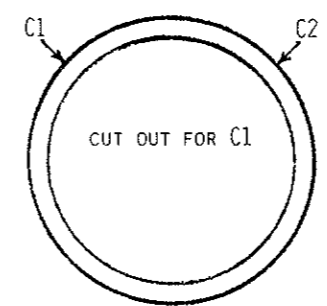

COWLING CUT FROM PLAN AND WRAP AROUND FORMER C2 TO FORM DRAG RING

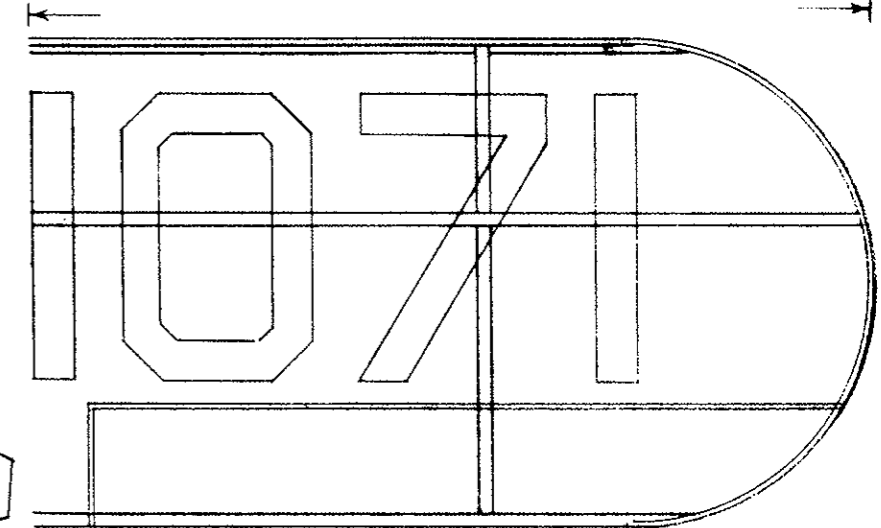

CUT THIS SECTION OF WING FROM PLAN AND JOIN TO MAIN WING BY MATCHING ARROWS

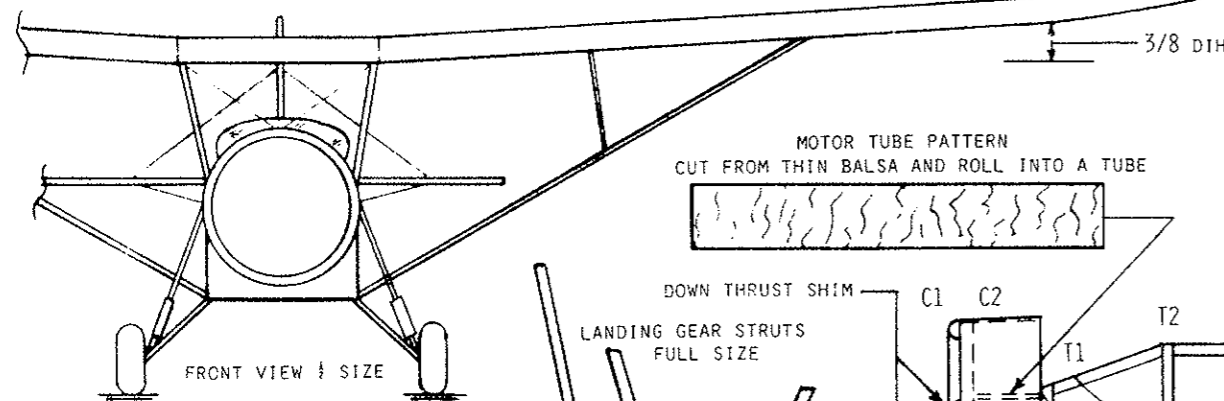

FRONT VIEW 1/2 SIZE

MOTOR TUBE PATTERN CUT FROM THIN Balsa AND ROLL INTO A TUBE

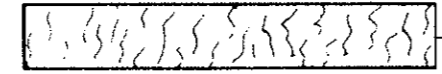

DOWN THRUST SHIM
LANDING GEAR STRUTS FULL SIZE

FULL SIZE JURY STRUTS

SHOCK ABSORBER

SHOCK ABSORBERS

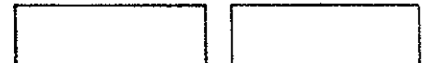

CUT FROM PLAN AND WRAP AROUND STRUT

FULL SIZE WING STRUTS

FAT DOUGHNUT WHEELS MAKE FROM Balsa WOOD USE PIN FOR AXLE

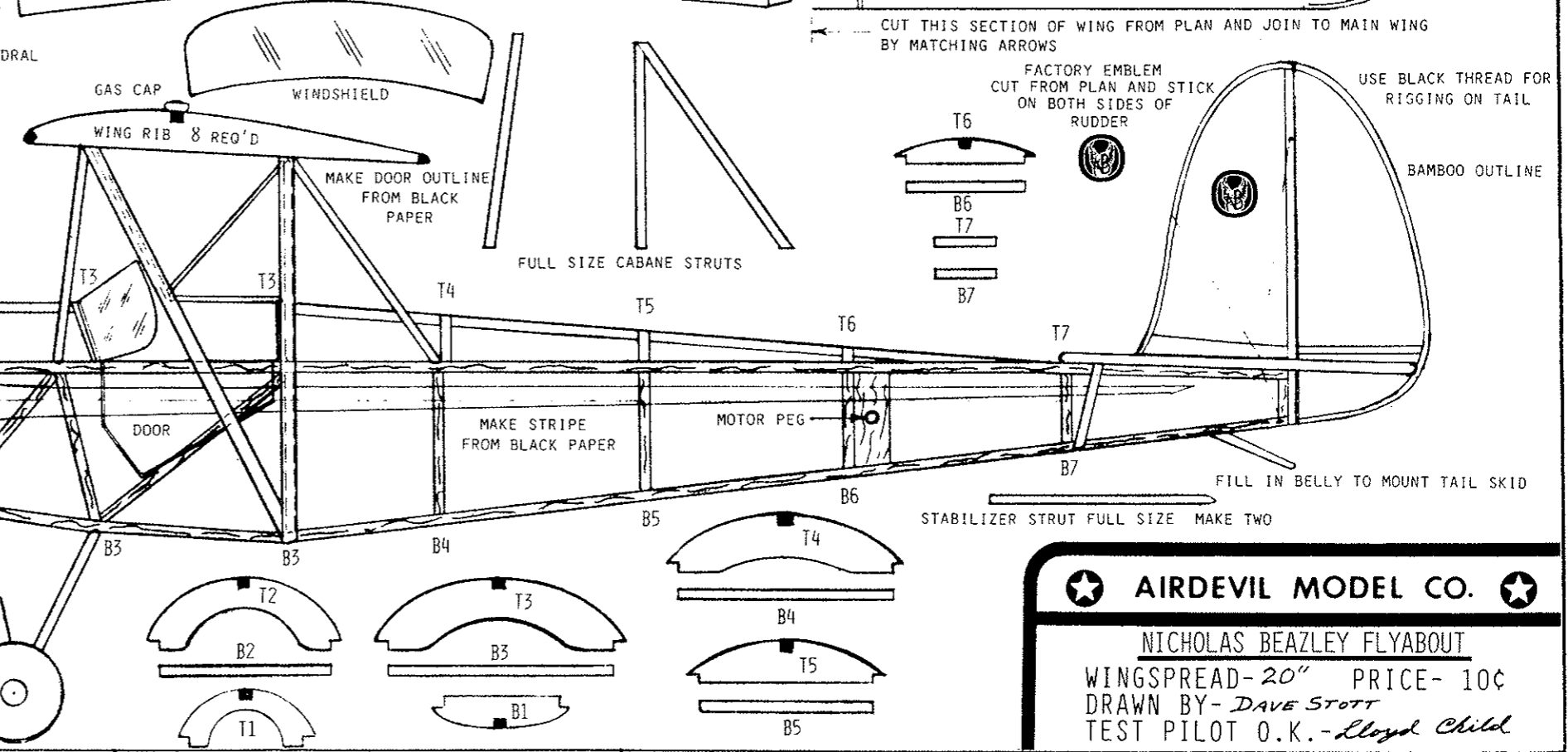

AIRDEVIL MODEL CO.

NICHOLAS BEAZLEY FLYABOUT
WINGSPREAD-20" PRICE- 10c
DRAWN BY- DAVE STOTT
TEST PILOT O.K. - Lloyd Child

11.19.38