

BUILD WASHOUT INTO WING TIPS BY PLACING A 1/32 SHIM UNDER RIB D AND A 1/16 SHIM UNDER RIB E AS SHOWN ON PLAN. MAKE SHIMS FROM Balsa SCRAP.

TO SET DIHEDRAL PLACE 5/8 HIGH BLOCK UNDER RIB E ON EACH WING. CENTER SECTION IS FLAT.

CUT 2 EACH TAPERED LEADING EDGE, SPAR, AND TRAILING EDGE FROM 1/16 SHEET Balsa AS SHOWN ABOVE

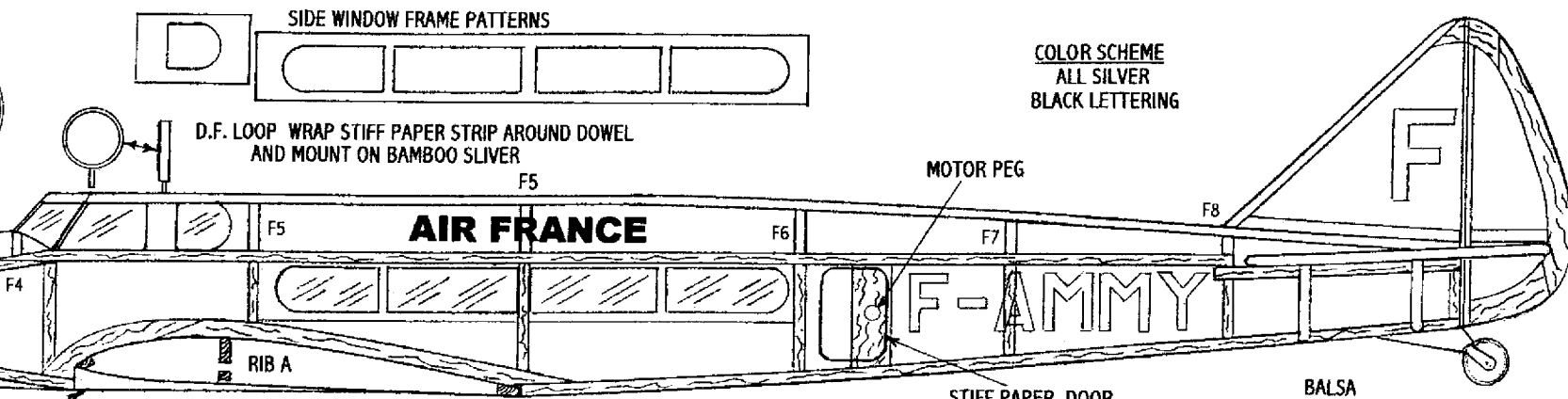
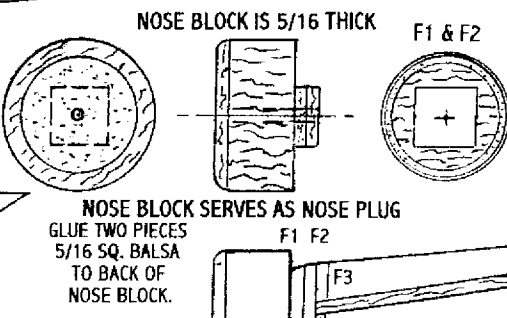
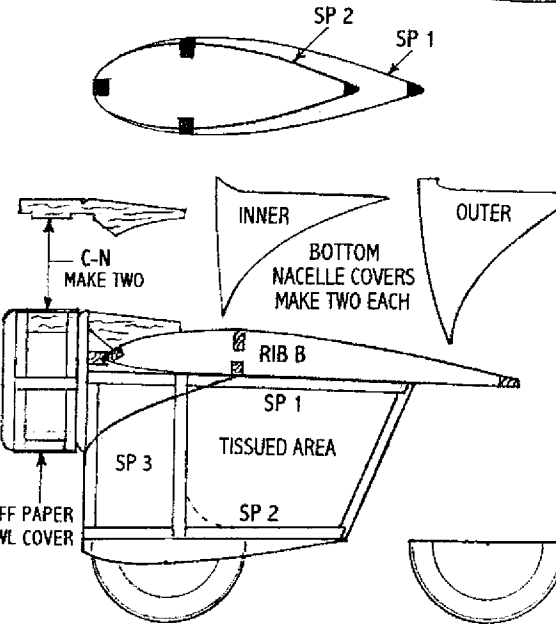
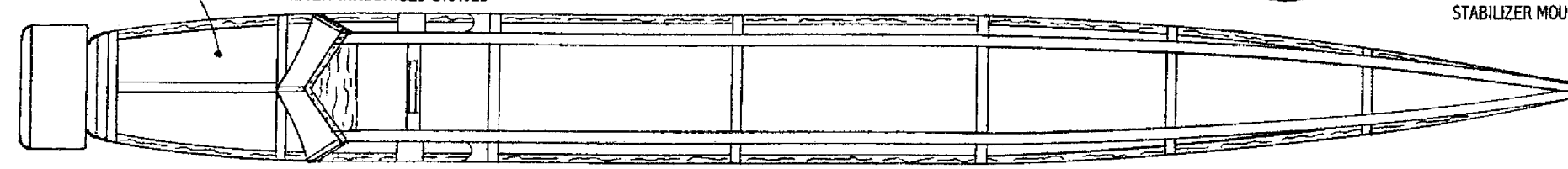
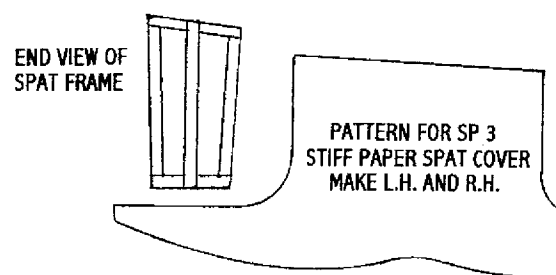
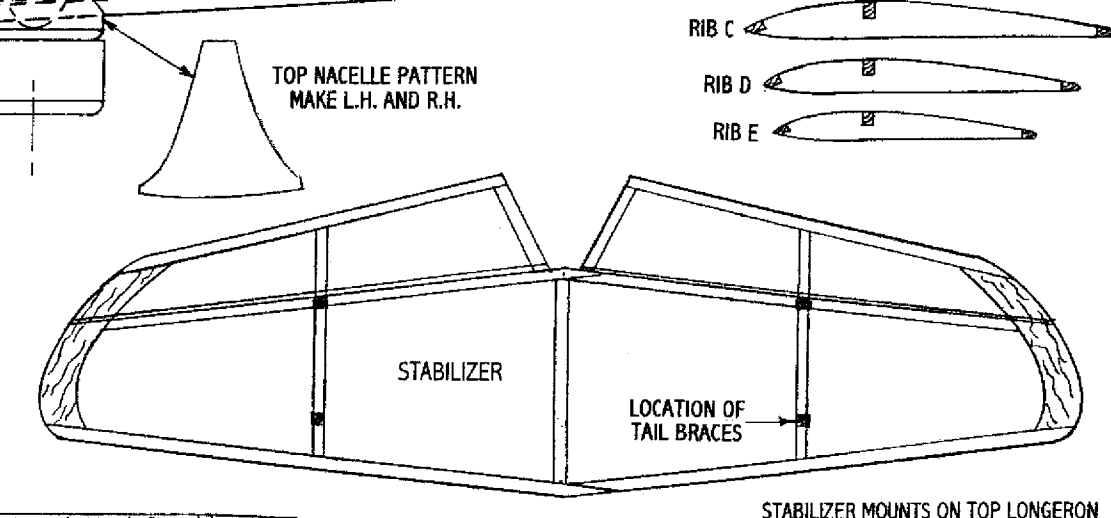
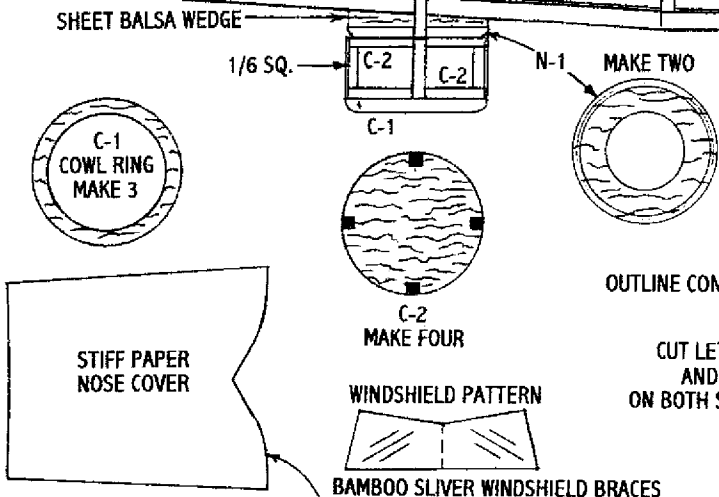
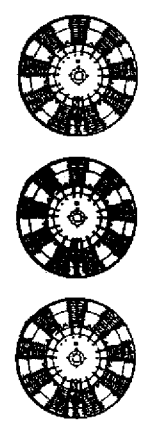
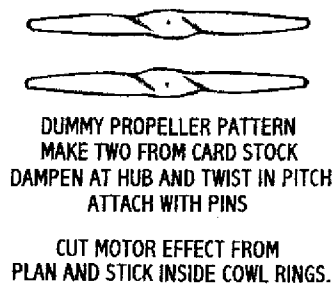
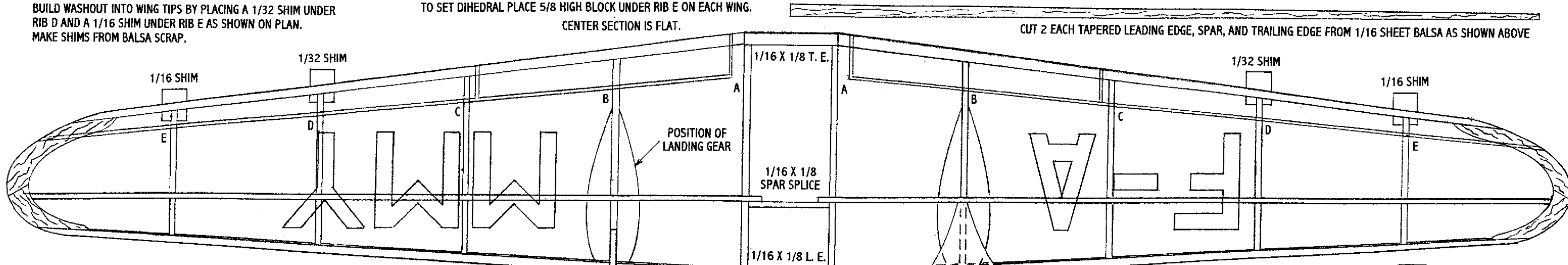

COLOR SCHEME
ALL SILVER
BLACK LETTERING

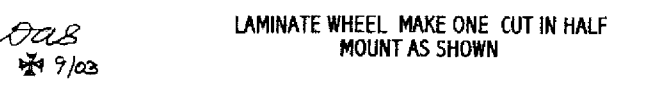
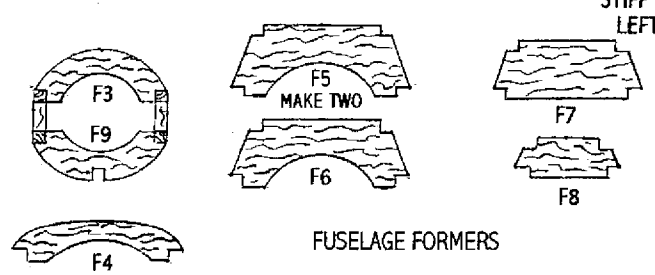
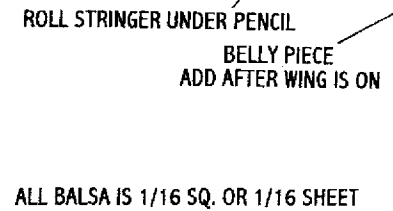

ALL Balsa IS 1/16 SQ. OR 1/16 SHEET

CURVE STIFF PAPER PARTS BY ROLLING AROUND DOWEL OR PENCIL



DEWOITINE D 332 AIRLINER
BY DAVE STOTT
www.flying-models.com

DAB
9/03