

1/16" Brass Tubing, either thread wrapped and glued to music wire or thin copper wire wrapped and soldered to music wire. Or you can use a Small Peck Button.

1/32 " Music Wire Bind with thread and glue.

Motor Stick can be made from 1/8" x 3/8" Balsa, or can be a rolled balsa tube to save weight.

Complete Stab is Red. Plane overall white. Stripe down side of Plane is Red, continuing up fin, Spinner Red, Stripe on wheel pants Red. White G-BOPD on fuse side and BD4 on fin White. UK Red White and Blue flag on fin.



.025 Music Wire Bind with thread and glue.

Top View of Motor Stick

.025 Music Wire
Wheels, your choice. If going with the wheel pants, the wheels do not need to rotate.

All structure is 1/16" square or sheet unless otherwise noted. Prototype flew well with a stock Delta dart 5.5" plastic prop, shaved to balance.

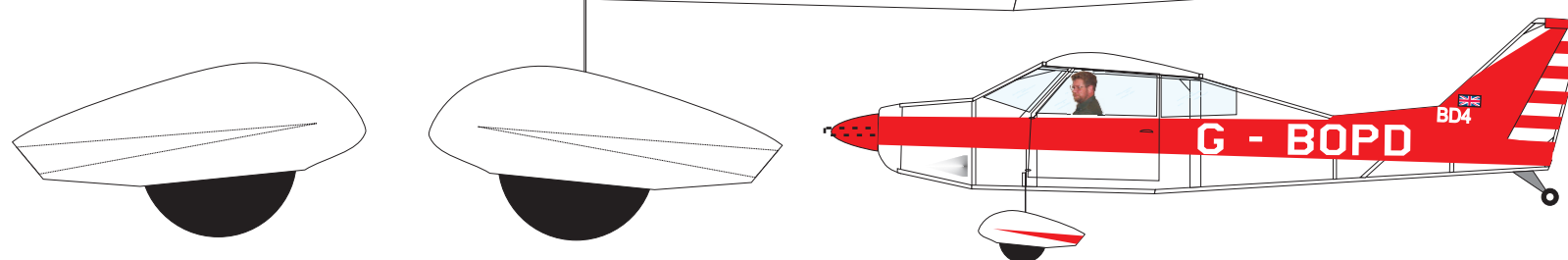
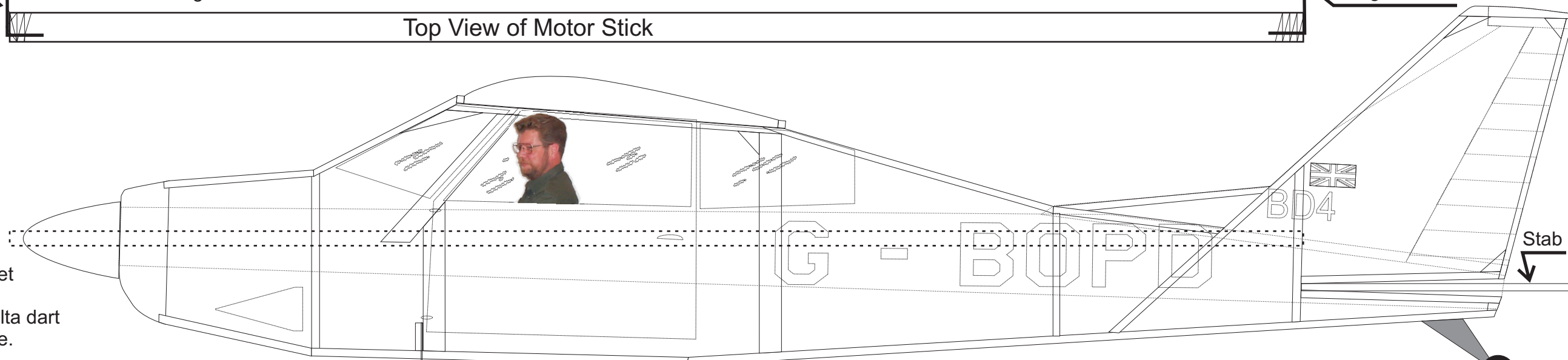

Bede-4 Nocal

For FAC Competition

Designed and Drawn by
Chris A. Boehm 11/2011
merlin236@comcast.net